

# COBBLE SERIES

## Garage Door Openers

### USER MANUAL

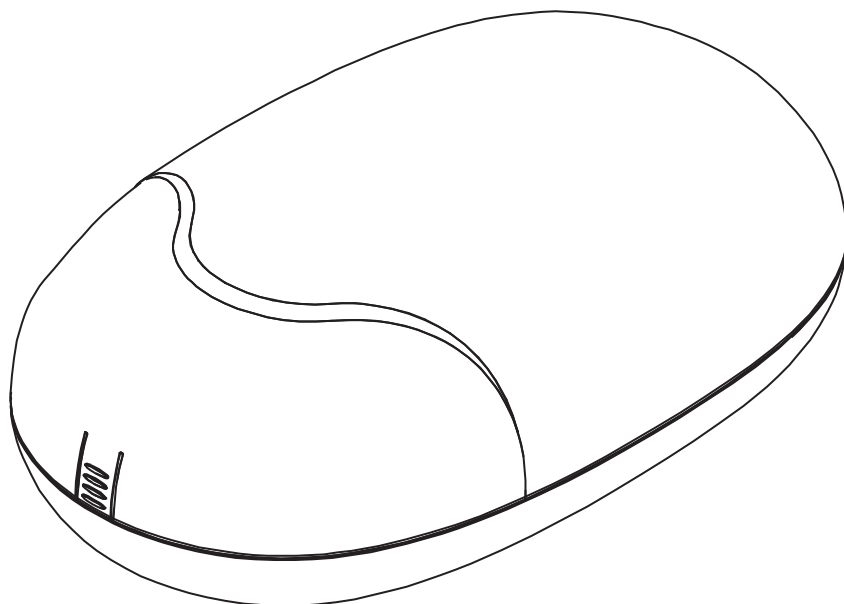

Reuse  
Reduce  
Recycle





# INDEX

1. Warnings	2
2. Product description	3
2.1 Applications	3
2.2 Description of the automation	3
3. Installation	4
3.1 Inventory of a garage door opener	4
3.2 Rail assembly	5
3.3 Attach the rail to the motor	6
3.4 Attach the rail on the header wall and ceiling	6
3.5 Connect release section to the garage door	7
3.6 Final steps before system learning	8
3.7 Introduction of the emergency release	8
4. Connection	9
4.1 Accessories connection	9
4.2 Door position for start-up phase	9
4.3 Transmitter memorizing and erasing process	9
4.4 System learning, reset process, and led display	10
4.5 Programmable function indication led	10
4.6 How to set the parameter	10
4.7 Programmable function setting	11
5. Function of external accessories	12
5.1 Function of photocells	12
5.2 Function of external push button	12
6. Specification	12

## 1. WARNINGS

### **WARNING :**

**Please read this instruction manual carefully before the installation.**

**This manual is exclusively for qualified installation personnel. TMT Automation Inc. is not responsible for improper installation and failure to comply with local electrical and building regulations.**

**Keep all the components of Cobble garage opener system and this manual for further consultation.**

- In this manual, please pay extra attention to the contents marked by the symbol: 
- Be aware of the hazards that may exist in the procedures of installation and operation of the garage opener system. Besides, the installation must be carried out in conformity with local standards and regulations.
- If the system is correctly installed and used following all the standards and regulations, it will ensure a high degree of safety.
- Make sure that the door works properly before installing the garage opener system and confirm the doors are appropriate for the application.
- Do not let children operate or play with the garage opener system.
- Do not cross the path of the garage opener system when operating.
- Please keep all the control devices and any other pulse generator away from children to avoid the system being activated accidentally.
- Do not make any modifications to any components except that it is mentioned in this manual.
- Do not try to manually open or close the doors before you release the opener.
- If there is a failure that cannot be solved and is not mentioned in this manual, please contact qualified installation personnel.
- Do not use the garage opener system before all the procedures and instructions have been carried out and thoroughly read.
- Install warning signs (if necessary) on the both sides of the door to warn the people in the area of potential hazards.

## 2. PRODUCT DESCRIPTION

### 2.1 APPLICATIONS

Cobble garage door opener is applied for residential automation of up and over doors and sectional doors and has to be operated with electricity and it's forbidden to be operated by back-up batteries for normal use. Back-up batteries are only allowed for emergent operation when there is a power failure, and the carriage can be released by pulling the cord to move the door manually.

### 2.2 DESCRIPTION OF THE AUTOMATION

1). The following diagram of typical installation describes some terms and accessories of the door automation system:

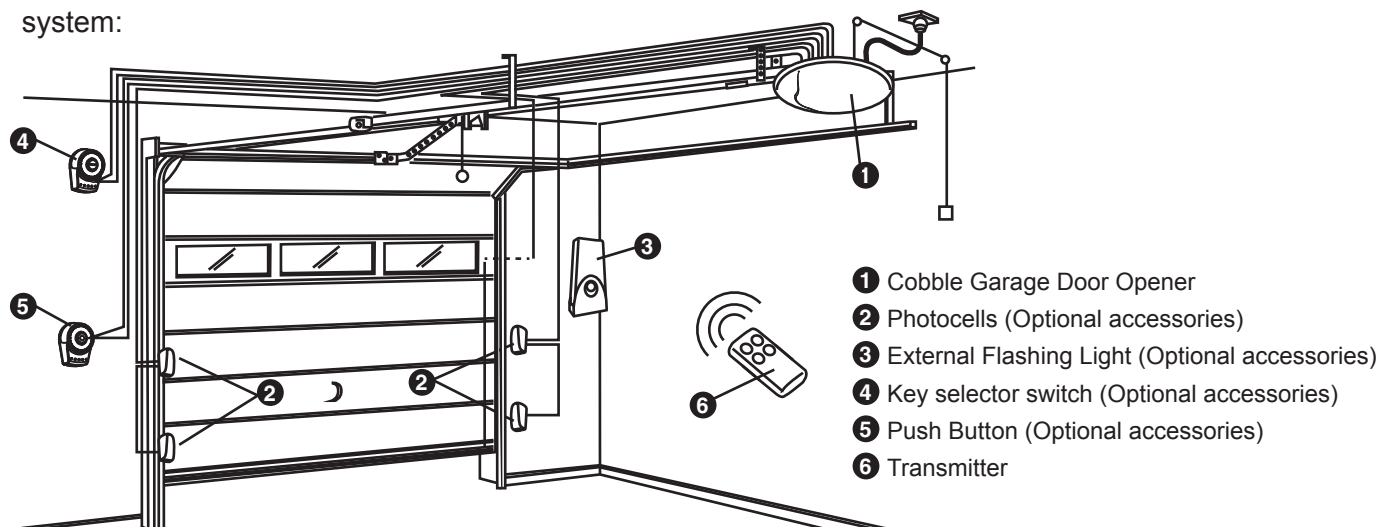

Please set stopper in the open limit position of the rack and after the setup is completed, then garage door opener can start the system learning process.

2). The indication of control panel

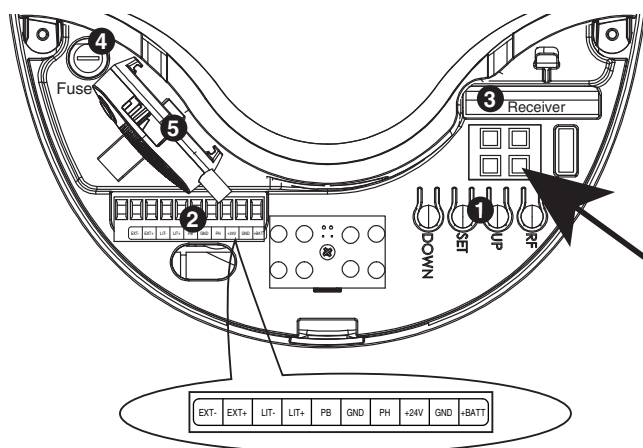

- 1 Operation buttons: Remote Function key (RF), Setting key (Set), UP key (Up), DOWN key (Down).
- 2 Connection terminal of Optional accessories
- 3 Radio receiver board
- 4 Fuse
- 5 Wifi Box (Refer to Wi-Fi Box User Manual)

3). The LED indication

- 1 The power indicator is on the bottom right of the display. When the power is connected, the LED dot indicator is alight.
- 2 When entering to the power-saving mode, the LED power indicator is flashing ( light for 0.5 second and then no light for 5 seconds )

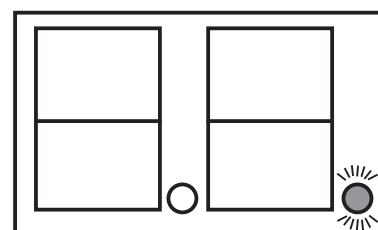

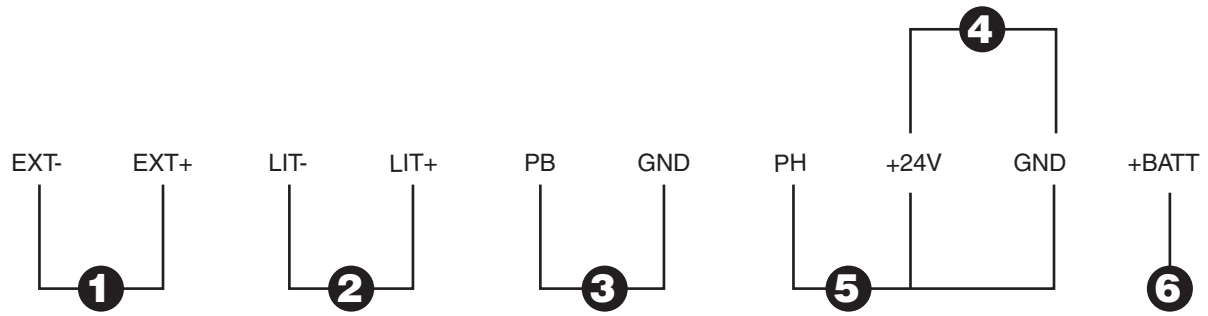

- 1**  
Key Selector
- 2**  
Flashing Light
- 3**  
Push Button

- 4**  
TX1
- 5**  
RX1

- 6**  
Battery

### 3. Installation

#### 3.1 Inventory of a garage door opener

- 1**  
 Iron rail x3
- 2**  
 Front hold bracket
- 3**  
 Rear pulley bracket
- 4**  
 Front pulley bracket
- 5**  
 Metal Chain
- 6**  
 Slide block
- 7**  
 Release Rope
- 8**  
 Release trolley
- 9**  
 Motor hold bracket x2
- 10**  
 Ceiling hold bracket
- 11**  
 Header bracket
- 12**  
 Door bracket
- 13**  
 Ceiling bracket
- 14**  
 Curved door arm
- 15**  
 Straight door arm

#### Hardware Inventory

- 16**  
 Blocker x1
- 17**  
 R-type pin x2
- 18**  
 Self-tapping screws x4
- 19**  
 M8\*20 HEX bolt x4
- 20**  
 M6\*14 HEX bolt x4
- 21**  
 Metric bolt x2
- 22**  
 Clevis Pin x2
- 23**  
 M8\*8 Nut x6
- 24**  
 M6\*6 Nut x8

#### Optional for 1pcs x 1M Rail

- 25**  
 Junction x2
- 26**  
 Ceiling support bracket

## 3.2 Rail assembly

- 1** Assemble the front and middle rail with the junction, and make sure is located at the middle of the protruding point.

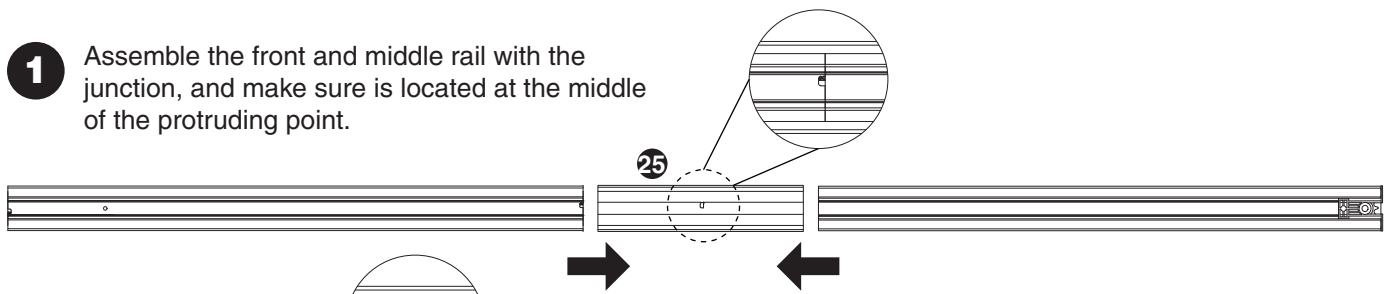

- 2** Assemble the back and middle rail with another junction, and make sure is located at the middle of the protruding point.

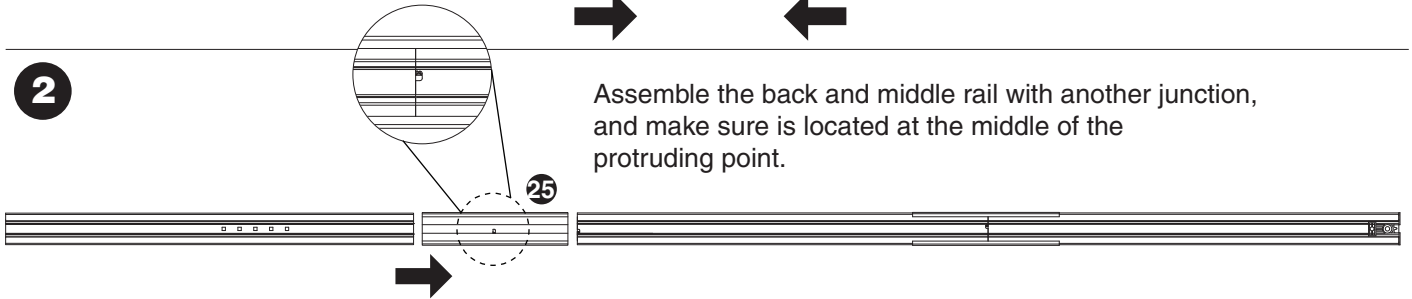

### Complete



- 3**
- Put the (6) Slide block in the rail track, and put the (5) Metal chain in the rail track. Make sure the metal mortise part is on right side of the rail.
  - Cross the (5) Metal chain through the (4) front pulley bracket, the (3) rear pulley bracket, and the (6) Slide block. The metal mortise part should be placed in the middle of the whole rail.
  - Connect the (5) Metal chain.

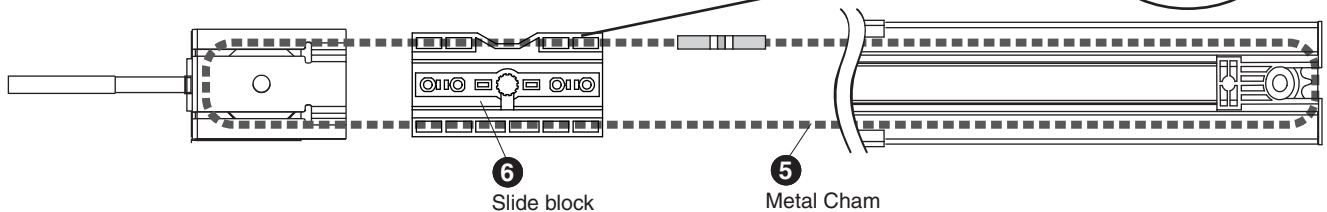
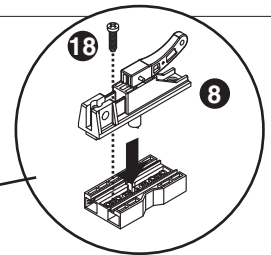

- 4**
- Remove the nut and the spring in the (4) Front pulley bracket. Make sure the metal chain is placed in the gap of the pulley on the two sides. Insert the (2) Front hold bracket against the rail. Use the spring and the nut to adjust the tightness of the (5) Metal chain.

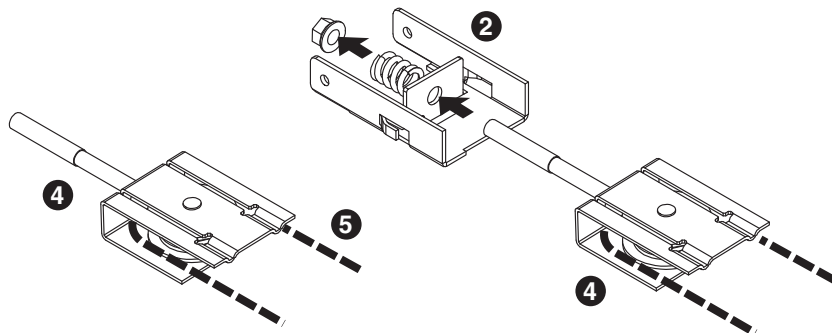

### Complete

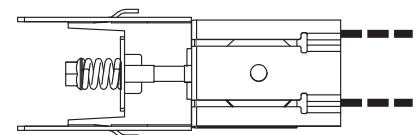

### Complete



### 3.3 Attach the rail to the motor

1. Connect the insertion gap of the (3) Rear pulley bracket to the output shaft of the motor.
2. Fasten the rail on the motor with (9) motor hold bracket and the Hex nuts (24).
3. Fasten the (10) Ceiling hold bracket and (13) Ceiling bracket at the rear side between the motor and the rear blocker with Hex bolt (20) and Hex nuts (24)

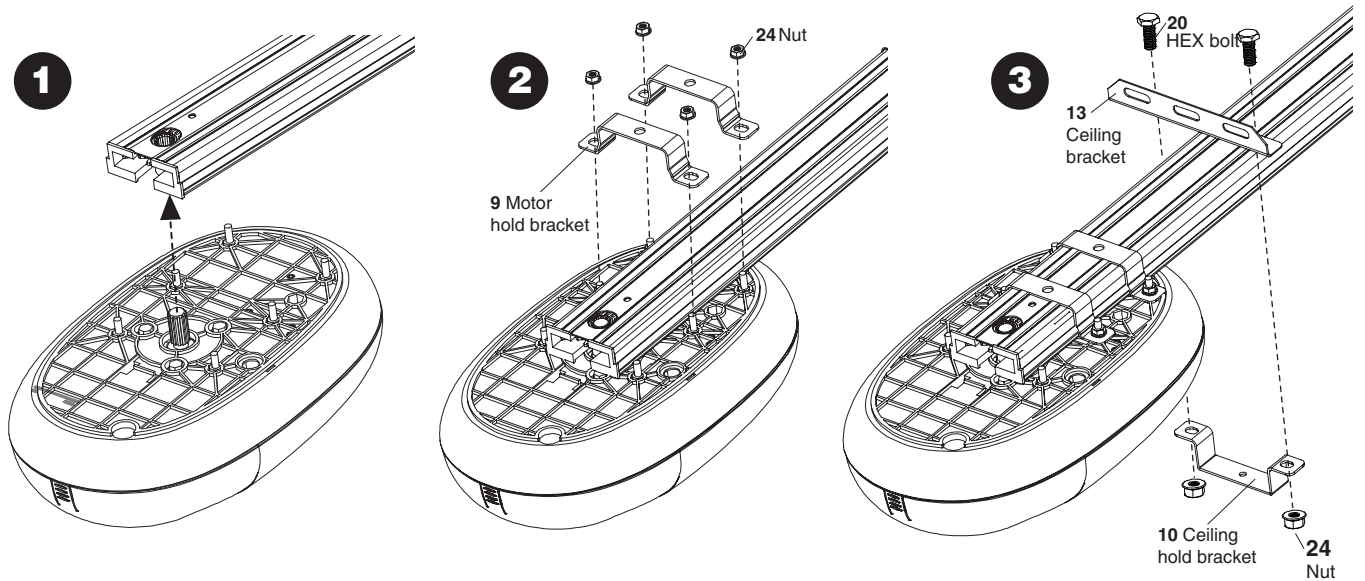

### 3.4 Attach the rail on the header wall and ceiling

1. Position (11) Header bracket on the header wall.  
 \*It is recommended that positioned at the center of the garage door.  
 \*The installation height of the (11) Header bracket varies from 30-50cm from the top of the garage door.
2. Install the (11) Header bracket with screws.
3. Attach the front rail to header bracket with bolts.
4. Attach the (13) Ceiling bracket on the crossbeam of ceiling with crews.

#### Attach Rail to the Header Bracket

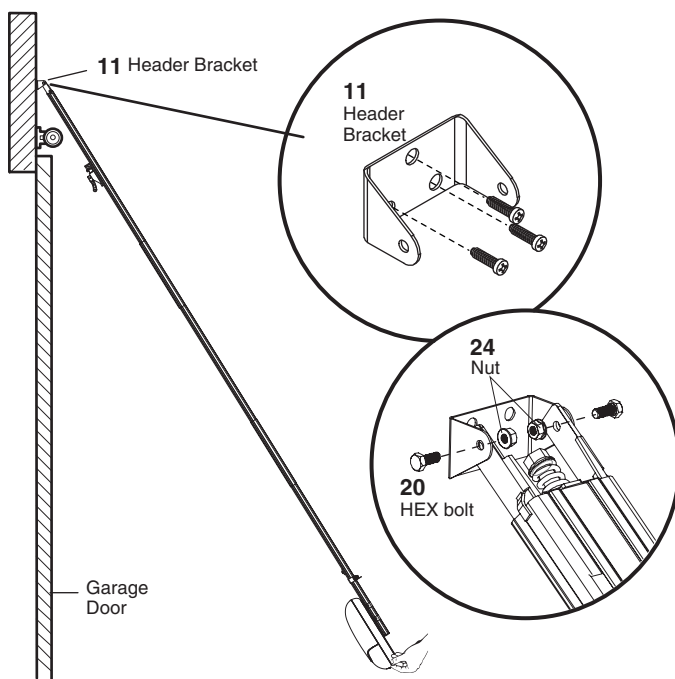

### CAUTION

To prevent damage, place the garage door on the top section to create a temporary support.

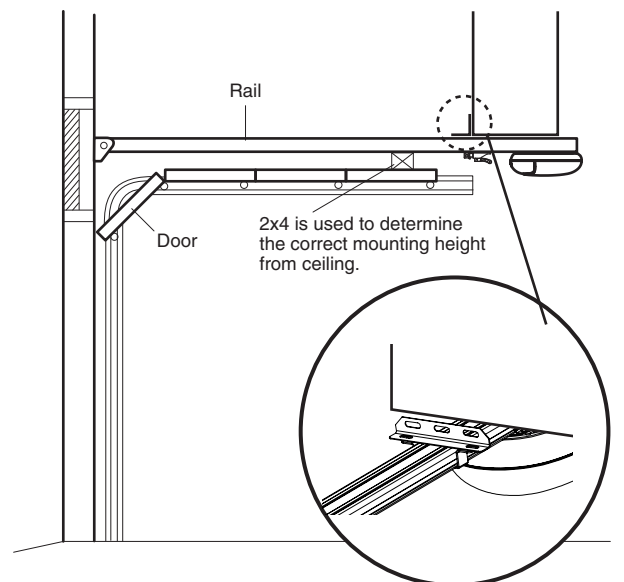

### 3.5 Connect release section to the garage door

#### 1 Connect the (7) Release rope on the (8) Release trolley

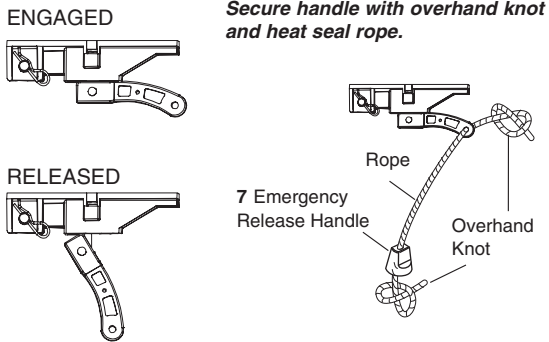

#### **! WARNING**

To prevent possible **SERIOUS INJURY** or **DEATH** from a falling garage door:

- If possible, use emergency release handle to disengage trolley **ONLY** when garage door is **CLOSED**. Weak or broken springs or unbalanced door could result in an open door falling rapidly and/or unexpectedly.
- **NEVER** use emergency release handle unless garage doorway is clear of persons and obstructions.
- **NEVER** use handle to pull door open or closed. If rope knot becomes untied, you could fall.

**NOTE:** Handle should hang 6 feet (1.5 m) above floor. Ensure that the rope and handle clear the tops of all vehicles to avoid entanglement.

### CONNECT DOOR ARM TO TROLLEY

#### 2 Pull the (7) Release rope to disengage the (8) Release trolley

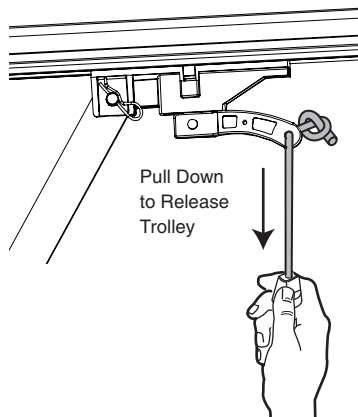

#### 3 Connect (15) Straight door arm to Release trolley

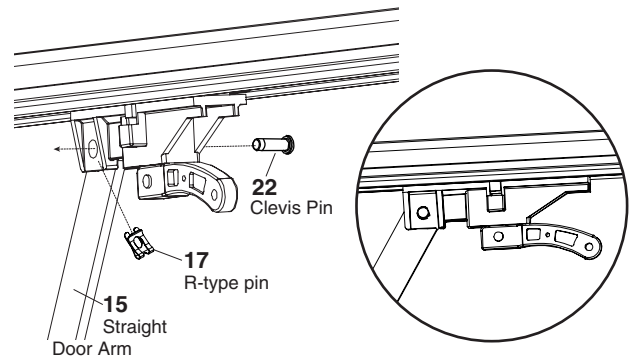

#### 4 Fasten the (12) Door bracket on the center of the garage door. Connect (14) Curved door arm to (12) Door bracket.

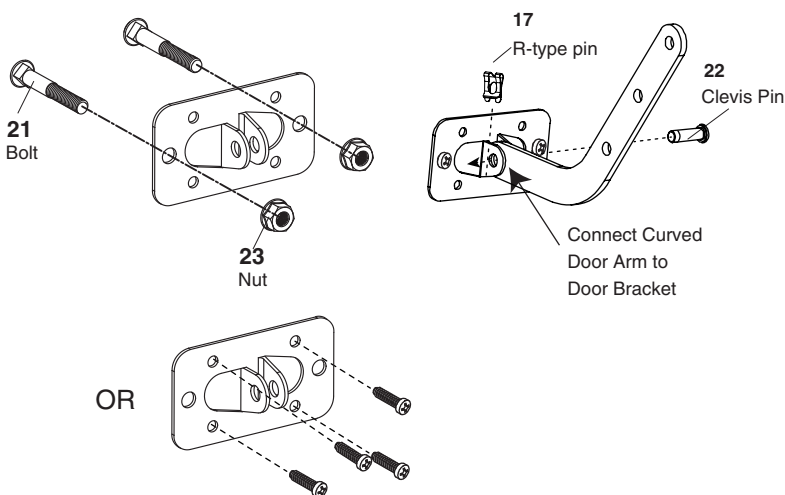

#### 5 Connect (14) Curved door arm and a straight door arm with bolts and nuts.

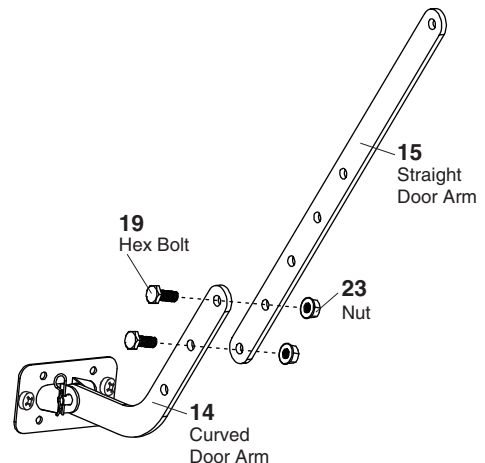



### 3.6 Final steps before system learning

1. Install the blocker the (16) Blocker on the door opened position.
2. Attached the warning sign to the (7) release rope.
3. Connect the power to the motor. Make sure the electric plug and socket are well connected.

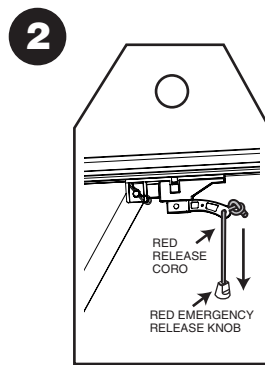
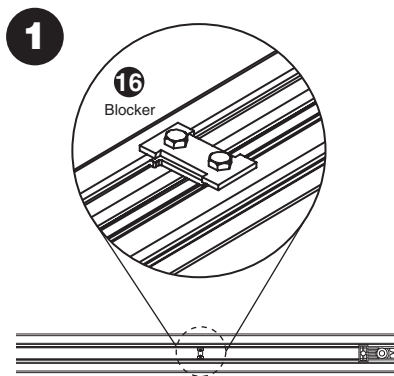

3

#### **⚠ WARNING**

To prevent possible **SERIOUS INJURY** or **DEATH** from electrocution or fire:

- Be sure power is not connected to the opener, and disconnect power to circuit **BEFORE** removing cover to establish permanent wiring connection.
- Garage door installation and wiring **MUST** be in compliance with all local electrical and building codes.
- **NEVER** use an extension cord, 2-wire adapter, or change plug in **ANY** way to make it fit outlet. Be sure the opener is grounded.

### 3.7 Introduction of the emergency release

1. Pull the (7) Emergency release rope to release the trolley. Make sure the trolley is disengaged. The garage door can be operated manually.
2. Before restarting the motor, manually move the garage door until the trolley is engaged.

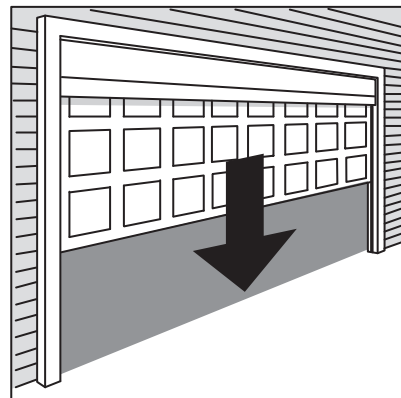
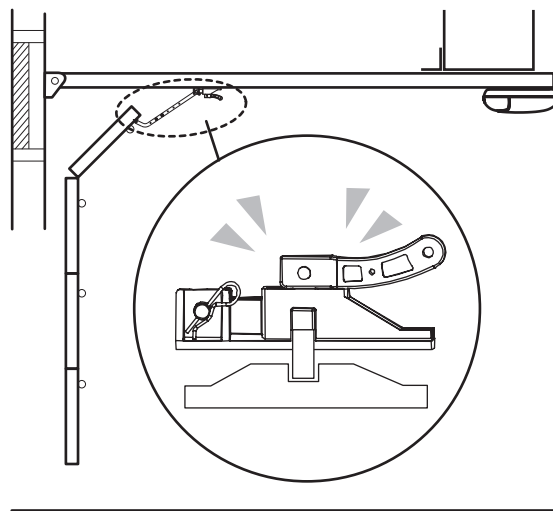
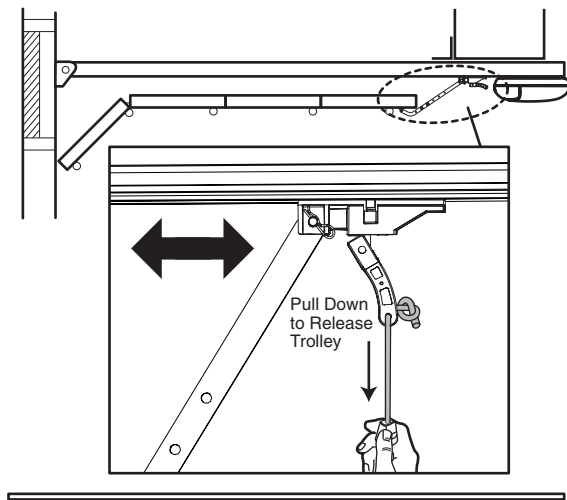

## 4. Connection

### 4.1 Accessories connection



Only carry out electrical connections once the electricity supply to the system has been switched off.

Disconnect any

A. Open the cover in order to access the electronic connection terminal of the Cobble Series garage gate opener.

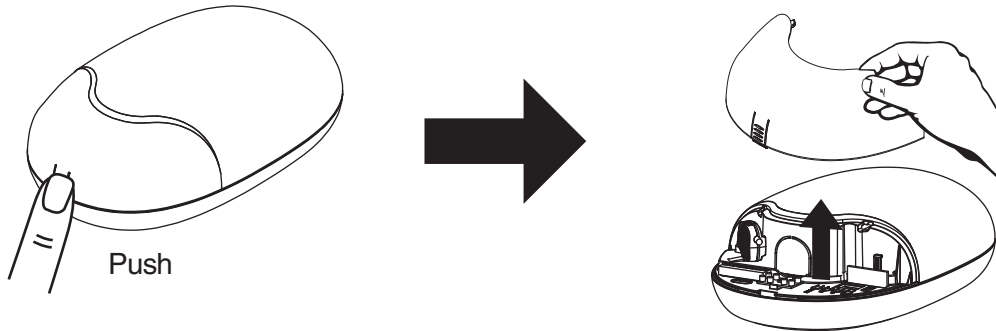

B. Connect the wires of each accessory on the terminal. (If necessary)

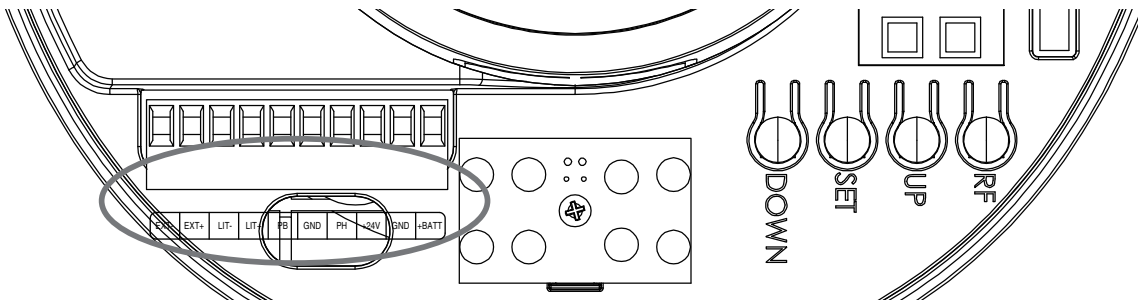

### 4.2 Door position for start-up phase

The manufacturers recommend you unhook the carriage and position the leaf at approximately half travel before starting the checking and start-up phase of the automation. This will ensure the leaf is free to move both during opening and closure.

Power supply connection

Connect the plug. If necessary, use a commercial adaptor if the plug on the Cobble Series unit does not correspond to the socket available. As soon as the system is powered, you should check the LED in the display. Make sure the LED display is ON.

Never cut or remove the cable supplied with Cobble Series garage opener. If not already available, the power socket of Cobble Series garage opener connection must be fitted by skilled and qualified personnel in strict observance of current legislation, standards and regulations.

The power supply line must be protected from short circuits and ground leakage.

### 4.3 Transmitter memorizing and erasing process

#### A. Transmitter Memorizing:

Press "RF Learn" button for 3 seconds, and the Display will show "CS"; then press the transmitter A button within 10 seconds; the "CS" will blink three times and show "CS". After 10 seconds without any movement, "CS" will be off. The transmitter learning is completed.

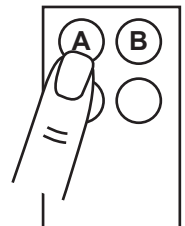

#### B. Erasing Transmitter Memory:

Press and hold "RF Learn" button for 10 seconds, the display will show "CS". When "CC" shows up, the memory is cleared.

#### C. Memorizing by memorized transmitter:

Press and hold A and B button for 5 seconds, LED light and external flash light will start to blink in the same time. Within 10 seconds, press any button of the un-memorized transmitter 2 seconds, the transmitter will be memorized after LED light and external flash light are off. To program by memorized transmitter, just can do the transmitter learning one by one.

## 4.4 System learning, reset process, and LED display

### A. System Learning:

**Step1:** Press and hold “RF” and “SET” buttons 3 seconds, the LED display shows “OL” and the motor enters system learning program.

**Step2:** Set up open limit and LED display shows “OL”. Press and hold “UP” or “DOWN” button to raise or descend the door. When the door moves to the proper open position, press “SET” button.

**Step3:** Set up close limit and LED display shows “CL”. Press and hold “UP” or “DOWN” button to raise or descend the door. When the door moves to the proper close position, press “SET” button.

**Step4:** The LED display blinks “GE” continuously. Press “SET” or “A” button of the transmitter to proceed operation testing. The LED display shows the operation current value in the process and memorizes overcurrent value.

**Step5:** The motor opens and closes automatically with full speed. The LED display shows “SO” while the system learning completes. The LED display shows “SF” while the system learning fails. The LED display will be off after 10 seconds.

**Note:** The overcurrent function and flashing light function will be activated automatically after learning process complete.

### B. Restore Default Setting:

Press “RF” and “DOWN” buttons for 3 seconds, and the LED display shows “CL” to recover the default settings.

### C. Motor current auto-detection

The LED display shows the current consumption of the motor



During the system learning procedure, the control panel will automatically detect the current consumption from each motor, indicate the resistance level of the gate while the motor operation. If this reading increase instantly or stay in high reading, please check if any object in between of the gate moving area, and contact your installer for inspection.

## 4.5 Programmable function indication led

LED Display	Programmable Functions	LED Display	Programmable Functions
	Start transmitter learning mode.		Operation testing
	Cleaned all studied transmitter.		System Learning Fail.
	Set up Open Limit.		System Learning Completely.
	Set up Close Limit.		System setting clear

## 4.6 How to set the parameter:

Step 1: Press the “Set” key for 3 seconds, the display will show the function code.

Step 2: Choosing the setting by Up and Down keys, after having chosen the indicated item, press the Set key and enter the setting of this function. The second digit will be shown on the right of the display, indicating the related function (please refer below chart for details). Using the Up and the Down Keys to choose the setting function and press the Set key to save.

## 4.7 Programmable function setting

LED Display	Definition	Function	Value	Description
1	Deceleration Point (% full operation)	1-1	75%	1.The default setting is "1-3" 2. The door will reverse 2cm if overcurrent occur in last 10% distance.
		1-2	80%	
		1-3	85%	
		1-4	90%	
		1-5	95%	
2	Main Operation Key	2-0	Function off	1.The default setting is "2-1"
		2-1	A Key	
		2-2	B Key	
		2-3	C Key	
		2-4	D Key	
3	Lighting Key	3-0	Function off	1.The default setting is "3-2"
		3-1	A Key	
		3-2	B Key	
		3-3	C Key	
		3-4	D Key	
4	External Device Key	4-0	Function off	1.The default setting is "4-3"
		4-1	A Key	
		4-2	B Key	
		4-3	C Key	
		4-4	D Key	
5	Safety Device Function Mode	5-0	Function off	1.The default setting is "5-0 "
		5-1	System stops when triggered	
		5-2	While opening, unobstructed upward motion. While closing, door stops when sensor is triggered.	
6	Alarm Buzzer	6-1	Function off	1.The default setting is "6-1" 2. IF the door left opened for longer than 10mins then buzzer start beeping and turn off until the door been closed.
		6-2	Function on	
7	Auto-closing	7-1	Function off	1.The default setting is "7-1"
		7-2	30 sec	
		7-3	60 sec	
		7-4	90 sec	
		7-5	120 sec	
		7-6	150 sec	
		7-7	180 sec	
		7-8	210 sec	
		7-9	240 sec	
8	Lighting	8-1	Function off	1.The default setting is "8-4"
		8-2	LED light starts running 1 minute	
		8-3	LED light starts running 2 minutes	
		8-4	LED light starts running 3 minutes	
9	Overcurrent reaction	9-1	Stop when overcurrent occur	1.The default setting is "9-2"
		9-2	Opening phase: Stop when overcurrent Closing phase: Reverse 10 cm when overcurrent	
		9-3	Reverse to the end when overcurrent.	
A	Overcurrent setting	1-0	Learning current add 0.2A as overcurrent	1. The default setting is "3-0"
		2-0	Learning current add 0.4A as overcurrent	
		3-0	Learning current add 0.5A as overcurrent	
		4-0	Learning current add 0.6A as overcurrent	
		5-0	Learning current add 0.8A as overcurrent	
		6-0	Learning current add 1.0A as overcurrent	
		7-0	Learning current add 1.2A as overcurrent	
		8-0	Learning current add 1.4A as overcurrent	
		9-0	Learning current add 1.6A as overcurrent	
9-9	Learning current add 1.8A as overcurrent			

LED Display	Definition	Function	Value	Description
C	Overcurrent setting of open limit	C1	2A as overcurrent value of open limit	1. The default setting is "C-3"
		C2	3A as overcurrent value of open limit	
		C3	4A as overcurrent value of open limit	
		C4	5A as overcurrent value of open limit	
		C5	6A as overcurrent value of open limit	
		C6	7A as overcurrent value of open limit	
		C7	8A as overcurrent value of open limit	
E	Overcurrent setting of close limit	E1	2A as overcurrent value of close limit	1. The default setting is "E-3"
		E2	3A as overcurrent value of close limit	
		E3	4A as overcurrent value of close limit	
		E4	5A as overcurrent value of close limit	
		E5	6A as overcurrent value of close limit	
		E6	7A as overcurrent value of close limit	
		E7	8A as overcurrent value of close limit	
F	Power supply for +24V terminal	F1	Continuously power supply	1. The default setting is "F-1" 2. Sleep mode: Power supply only when motor is operating
		F2	Sleep mode	

## 5. Function of external accessories

### 5.1 Function of photocells

Gate Status	The reactions of the photocells when detecting obstacles
Closed	No effect. Photocells maintain in the inactive status.
Opened	Forbidden to move. If setting the automatic closing function, the door will reload automatic closing time.
Stop during moving	Forbidden to move. If setting the automatic closing function, the door will reload automatic closing time.
Closing	Stop closing immediately and open. If setting the automatic closing function, the door will reload automatic closing time.
Opening	Stop and wait for a next command. If setting the automatic closing function, the door will reload automatic closing time.

### 5.2 Function of external push button:

Operation logic of door when press the push button: **open-stop-close-stop**

## 6. Specification

Garage Door Opener	Cobble 60	Cobble 80	Cobble 100	Cobble 120
Volt	AC 220V / 110V ; 50Hz~60Hz	AC 220V / 110V ; 50Hz~60Hz	AC 220V / 110V ; 50Hz~60Hz	AC 220V / 110V ; 50Hz~60Hz
Motor volt	DC24V	DC24V	DC24V	DC24V
Power	72W	80W	100W	120W
Force	600N	800N	1000N	1200N
Remote frequency	433.92MHZ	433.92MHZ	433.92MHZ	433.92MHZ
Max door area	8-10m <sup>2</sup>	10-12m <sup>2</sup>	12-14m <sup>2</sup>	14-16m <sup>2</sup>
Temperature range	-20°C ~ +50°C	-20°C ~ +50°C	-20°C ~ +50°C	-20°C ~ +50°C
Rail length	3.0m/3.3m	3.0m/3.3m	3.0m/3.3m	3.0m/3.3m
Running speed	140mm/sec	140mm/sec	140mm/sec	140mm/sec

